



Horizontal *Aquacon*[®] Vessels

EI 1596 1st Edition Monitor

Specification Qualified

HA Series

Horizontal *Aquacon*[®] for Aircraft Fueling Trucks, Hydrant Carts, and Cabinets

FEATURES

- Positive Protection Against Water and Dirt
- Compact Design
- ASME Code Qualification
- Field Proven Performance

DESCRIPTION

Compact HA Series *Aquacon*[®] vessels are designed to utilize 6" outside-to-inside flow *Aquacon*[®] elements meeting the latest edition of the EI 1583 for aviation fuel filter monitors with absorbent type elements.

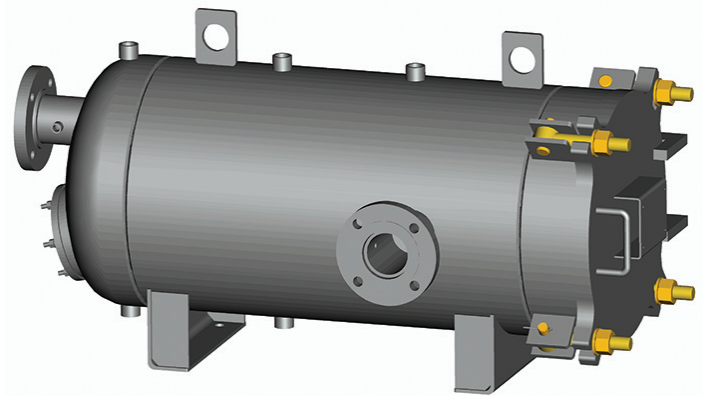

SPECIFICATIONS

- 150 PSI ASME Code Construction
- 220 psid (15 bar) Hydrotest Pressure for Deckplate
- Carbon Steel Construction
- RF Flanged or Victaulic Connections
- Swing Bolted Closure
- Buna-N O-Ring Cover Seal
- Mil-PRF-4556 Epoxy Coated Interior, Primed Exterior

RECOMMENDED ACCESSORIES

- Automatic Air Eliminator
- Pressure Relief Valve
- Manual Drain Valve(s)
- Differential Pressure Gauge
- Sampling Probes
- ASME Code Stamp

*****CAUTION*****

**DO NOT USE WITH PRE-MIXED FUEL
CONTAINING ANTI-ICING ADDITIVES.**

VESSEL MODEL NUMBER	FLOW RATE		CARTRIDGES		WEIGHT W/SKID (LBS)	VOLUME US GALS
	US GPM	L/M	MODEL NO.	QTY		
HA829M	115	435	ACO-62901	1	265	8
HA844M	173	654	ACO-64401	1	300	12
HA1814M	232	878	ACO-61401	4	550	29
HA1829M	460	1,741	ACO-62901	4	600	44
HA2229M	805	2,611	ACO-62901	7	720	56
HA2244M	1,211	3,928	ACO-64401	7	800	75

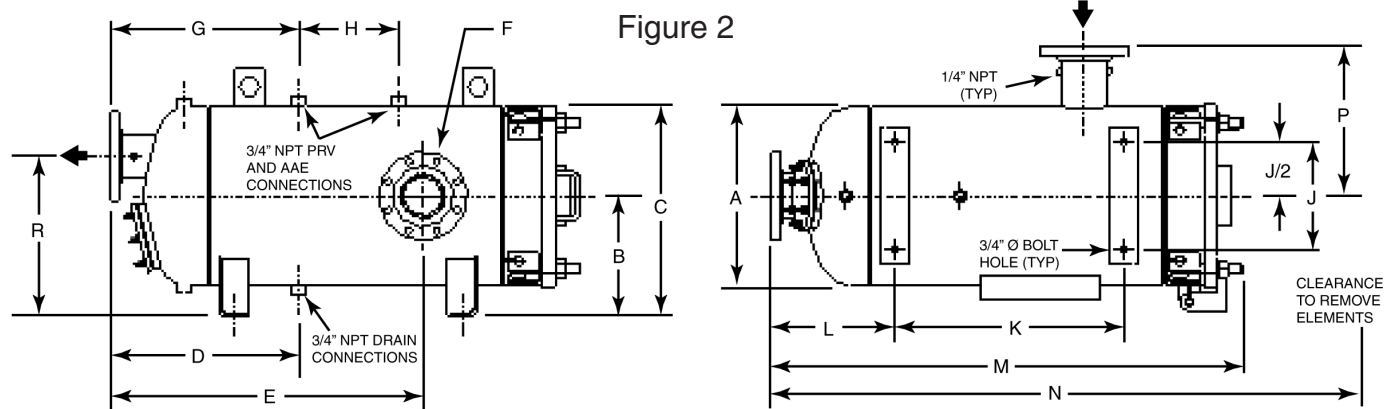
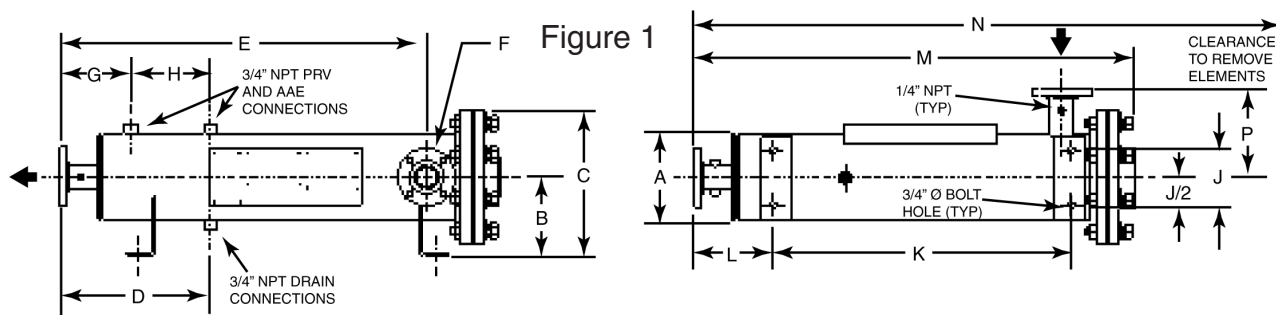

VESSEL MODEL NUMBER	Fig.	DIMENSIONS IN INCHES															
		A	B	C	D	E	F	G	H	J	K	L	M	N	P	R	
HA829M	1	8 ^{5/8}	8	14 ^{3/4}	15 ^{1/4}	37	2	7 ^{1/4}	8	5 ^{1/2}	30	8	44 ^{3/8}	74	9	N/A	
HA844M	1	8 ^{5/8}	8	14 ^{3/4}	16	51 ^{1/2}	2	8	8	5 ^{1/2}	41	8	58 ^{5/8}	102	9	N/A	
HA1814M	2	18	12	21	12 ^{1/2}	18 ^{1/4}	4	12 ^{13/16}	8	10 ^{3/4}	10	12 ^{1/2}	32 ^{15/16}	48	15	16	
HA1829M	2	18	12	21	12 ^{1/2}	31 ^{9/16}	4	19	10	10 ^{3/4}	23	12 ^{1/2}	47 ^{7/16}	76	15	16	
HA2229M	2	22	15	28 ^{1/2}	14	32 ^{3/4}	6	20	10	16	25	14	49 ^{1/4}	78	17	20	
HA2244M	2	22	15	28 ^{1/2}	14	48	6	20	10	16	40	14	64 ^{1/4}	108	17	20	



Velcon products are sold and serviced by a world-wide representative network. To order, contact Headquarters or your LOCAL REPRESENTATIVE:

COMPANY HEADQUARTERS:
 Velcon Filters, LLC
 1210 Garden of the Gods Road
 Colorado Springs, CO 80907-3410
 Phone: 1.800.531.0180 / 1.719.531.5855
 Fax: 719.531.5690
 e-mail: vfsales@velcon.com
 www.velcon.com

MANUFACTURING PLANTS LOCATED AT:
 Colorado Springs, Colorado
 Sylacauga, Alabama
 Henryetta, Oklahoma

OFFICES AND AFFILIATES IN:
 Canada, Germany, Singapore, & Spain



Liquid Filtration
 and Separation
 Specialists