

## Low cost protection against dirt and water contamination of jet, gasoline, and diesel fuels.

### STANDARD DESIGN FEATURES

- Air Vent and Drain Valves
- Epoxy Coated Interior, Primed Exterior
- Threaded Base Coalescer Cartridge
- 100 PSI Design Pressure
- Choice of Three Second Stage Cartridge Options
- Differential Pressure Gauge
- Leg Assembly

### OPTIONAL FEATURES

- Male and Female Pipe Union
- Velcon CDF® Series Cartridges

The Velcon V818 series is designed for assuring CLEAN and DRY FUEL delivery at smaller installations. When the filter/separator is overloaded, secondary water defense can be obtained by using the Velcon CDF® Series cartridge option inside a Teflon® coated screen second stage. This option provides in a single vessel the ability to incorporate a three stage cartridge configuration comprising coalescers, separators, and CDF monitor cartridges to meet IP-1583 4th Edition Monitor Specs.

Installation is easy using standard pipe couplings. Male and female pipe union is available as an accessory for connection to the outlet to facilitate the installation and provide for quick cartridge changeout.

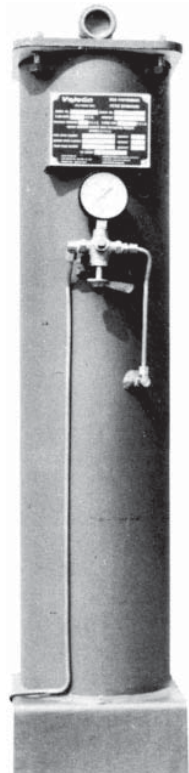

**Threaded Base  
Coalescer**

**Teflon® Coated  
Screen Separator  
With CDF® Cartridges**



**Pleated Paper  
Separator**

**Teflon® Coated  
Screen Separator**

® Teflon is a registered trademark of E.I. du Pont de Nemours & Co., Inc.

® CDF is a registered trademark of Velcon Filters, Inc.

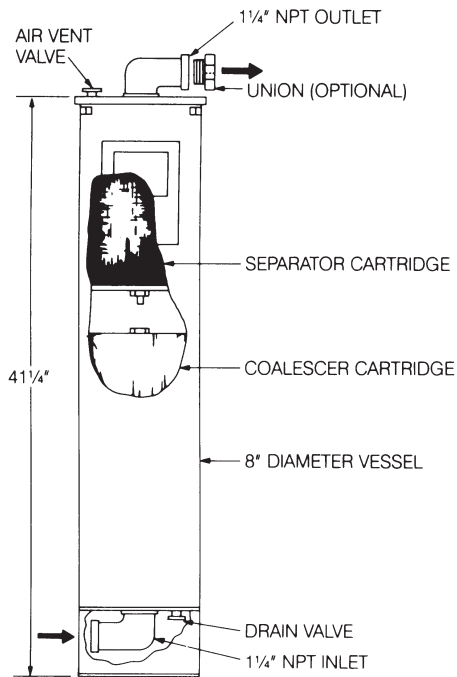

Model V818 Used With:	Flow Rates (USGPM)
Kerosene	
With CDF® Cartridges	50
Without CDF® Cartridges	40
Gasoline	60
Diesel Fuel	23

**\*\*\*CAUTION\*\*\***  
**DO NOT USE WITH PRE-MIXED FUEL CONTAINING ANTI-ICING ADDITIVES WHEN USING AS A THREE-STAGE VESSEL WITH CDF MONITOR CARTRIDGES.**

Options for Cartridges and Accessories	Part Number for Model V818002	Part Number for Model V818001 (inc CDF Hardware)
Coalescer Cartridge (1 required per vessel) For use with jet fuel, gasoline For use with diesel fuel	I-6186T I-6184T	I-6186T N/A
CDF Cartridges (5 required per vessel)	N/A	CDF-210N
Separator Cartridge (1 required per vessel) Teflon coated screen Teflon coated screen (no provision for CDF cartridges) Pleated paper (no provision for CDF cartridges)	N/A SO-611C SO-611PLF3	SO-613GS N/A N/A
Accessories 1 1/4" male & female pipe union Spare CDF Cartridges (5 per set required)	71607 N/A	71607 CDF-210N

**PLEASE NOTE THAT YOU MUST SPECIFY ALL COMPONENTS REQUIRED**

**Sample specification:** For a 50 gpm Jet Fuel filter/separator with CDF Series cartridges, differential pressure gauge, pipe union, one spare coalescer cartridge and a spare set of CDF cartridges, specify the following:

Quantity	Part #	Description
1	V818001	Filter/Separator Vessel-50 gpm Jet Fuel
2	I-6186T	Coalescer Cartridges (one spare)
1	SO-613GS	Separator Cartridge
1	71607	Pipe Union
10	CDF-210N	CDF Series Cartridges (original plus spare set)
1	G-1045	Lid Gasket



Velcon products are sold and serviced by a world-wide representative network. To order, contact Headquarters or your **LOCAL REPRESENTATIVE**:

**COMPANY HEADQUARTERS:**  
 Velcon Filters, Inc.  
 1210 Garden of the Gods Road  
 Colorado Springs, CO 80907-3410  
 Phone: 1.800.531.0180 / 1.719.531.5855  
 Fax: 719.531.5690  
 e-mail: vfsales@velcon.com  
 www.velcon.com

**MANUFACTURING PLANTS LOCATED AT:**  
 Colorado Springs, Colorado  
 Sylacauga, Alabama

**OVERSEAS AFFILIATES:**  
 Frankfurt/M., Germany & Singapore

**Liquid Filtration  
 and Separation  
 Specialists**